

## Firetemp® SE

*Endothermic Spray*

### Description

Firetemp® SE spray is a latex-based, endothermic spray designed to stop the passage of fire, smoke, and fumes through fire-rated separations. Firetemp® SE spray forms a durable and flexible seal after curing.

### Uses

Firetemp® SE spray provides an effective firestop for joint assemblies, such as floor, floor to wall, wall, head of wall, bottom of wall, steel decking to wall, and curtain wall to slab edge, in any combination of wood, concrete, concrete block, steel and gypsum materials.

### Advantages

**Endothermic.** When exposed to high temperatures or fire, Firetemp® SE spray absorbs heat and provides a fire barrier.

**System Design.** For small and large joints, Firetemp® SE spray is designed to be part of a multiple component system used with mineral wool. This combination maximizes the firestopping properties.

**Simplified Installation.** Firetemp® SE spray is installed with standard commercial power spray equipment. Priming is not required before use.

**Versatility.** Firetemp® SE spray adheres easily to dry or damp concrete, wood, metal, and other common building material surfaces.

**Flexibility.** Firetemp SE spray accommodates up to 33 percent joint movement compression/extension. It remains flexible and fully resistant to water after curing.

**Compliance.** Firetemp® SE spray has been tested for a number of firestop installations and meets or exceeds the requirements of ASTM E 814, ASTM E 119, UL 1479, UL 2079, CAN/ULC S115, and CAN/ULC S101. Underwriters Laboratories (UL) is a third party, fire endurance testing agency accredited by ICBO, BOCA and SBCCI (National Evaluation Services) in the United States. All joint firestopping tests included dynamic use (up to 33% movement) in accordance with ICBO ESAC 30 for a total of 500 cycles.

### Additional Testing

Firetemp® SE spray becomes an integral component in a complete building system of walls, floors, and ceilings. For this reason, its physical compatibility to other products used in these complex configurations requires more than the routine firestopping product testing. The results of these additional tests are listed in Table 1. Firetemp® SE Spray Test Data.



Firetemp® SE spray has proven that it has all of the physical characteristics desired in a firestopping product. Once installed and cured, it has excellent stability, even after four weeks at freezing temperatures of -15°F (-26°C) and exposure to extreme temperatures of 300°F (149°C) for 24 hours. Dimensional changes were well within the accepted standards (<2% per ASTM C 356). Dynamic testing demonstrated Firetemp SE spray's highly elastic properties.

When tested per ASTM E 84, the flame spread was <25 and smoke developed was <50.

Corrosion and microbial growth were tested, using procedures outlined in ASTM C 665. Firetemp® SE spray does not promote the corrosion of steel, copper, or aluminum. Also, Firetemp® SE spray does not support mold growth.

### Availability

Firetemp® SE spray is supplied in 5 gal. (18.9 L) plastic pails.

### Coverage

Estimated product coverage is 12.5 square feet (1.2 sq. m) per gallon (3.78 L) when applied to a thickness of 1/8 inch (3 mm). For specific configurations check estimating chart.

### Technical Services

For technical assistance, call (303) 978-2536. Complete technical information and product literature is available from Johns Manville Product Information Center, 1-800-654-3103.

# Firetemp® SE

## Endothermic Spray

**Table 1. Firetemp® SE Spray Test Data**

Property	Firetemp® SE Spray
Density	72 pcf
PH	8
Viscosity	60,000 cps
Moisture Adsorption (Wt%)	< 4%
Solids Content (Wt%)	75%
Elasticity	up to 33%
UV Resistance (QEV High Intensity Cycle) 1500 hrs, 200 cycles	Pass
Stability (dimension, cracks, blisters, flexibility)	
Freezing: -15°F (-26°C), 28 days	Pass
75–120°F (24–49°C), 28 days	Pass
200°F (93°C), 24 hours	Pass
300°F (149°C), 24 hours	Pass
Dimensional Change	
Freezing: -120°F (-84°C), 28 days	< 0.3%
300°F (149°C), 24 hours	< 1.5%
Corrosion (ASTM C 665)	
Steel	Pass
Copper	Pass
Aluminum	Pass
Stress Corrosion Cracking for Austenitic Stainless Steel (ASTM C 692)	Pass
Microbial Growth (ASTM C 665)	Pass
Surface Burning Characteristics (ASTM E 84)	
Flame	10
Smoke	10
Smoke Toxicity NBS Chamber (ASTM E 800)	Pass

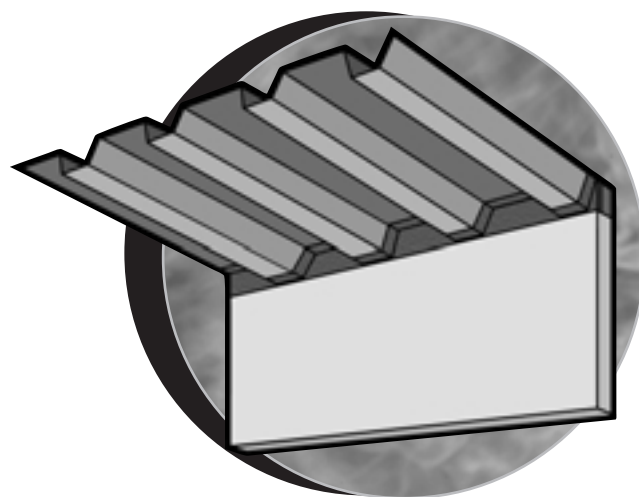

**Typical Top of Wall Joint**

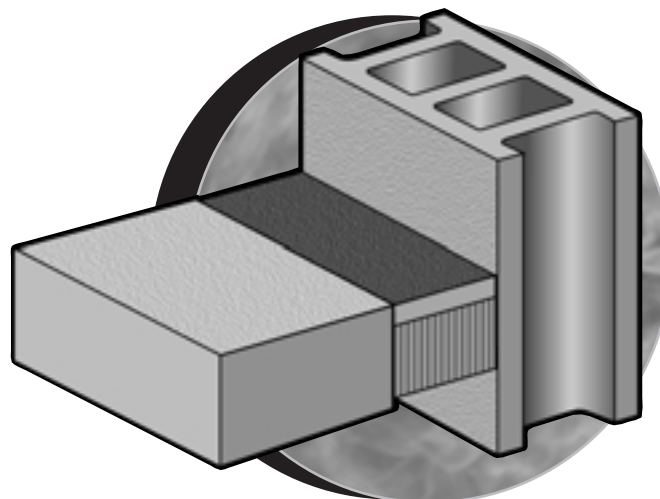

**Typical Wall and Floor Joint**

### Building Insulations

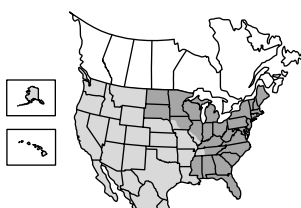

**United States** - (800) 644-4013  
**Canada** - (800) 272-9067

### Mechanical Insulations

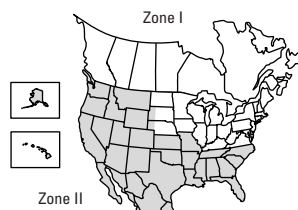

**Zone I** - (800) 334-2399  
**Zone II** - (800) 368-4431

### Product Information

(800) 654-3103

### Technical Assistance

(303) 978-2536

### International

(303) 978-3310

Fax: (303) 978-2627



**Johns Manville Insulations**  
Fire Protection Systems  
P.O. Box 5108  
Denver, CO 80217-5108 USA  
www.jm.com

The physical and chemical properties of Firetemp® SE represent typical, average values obtained in accordance with accepted test methods and are subject to normal manufacturing variations. They are supplied as a technical service and are subject to change without notice. Numerical flame spread and smoke developed ratings are not intended to reflect hazards presented by this or any other materials under actual fire conditions. Check with the Johns Manville Sales Office nearest you to assure current information.

**All Johns Manville products are sold subject to Johns Manville's Limited Warranty and Limitation of Remedy. For a copy of the Johns Manville Limited Warranty and Limitation of Remedy, call the 800 number below.** For information on other Johns Manville thermal insulations and systems and a copy of the Spec Data CSI formatted specification, call **800-654-3103**. To access automated fax-on-demand service in the United States and Canada, simply call **1-888-INSULFX** (1-888-467-8539) from a fax or phone.